

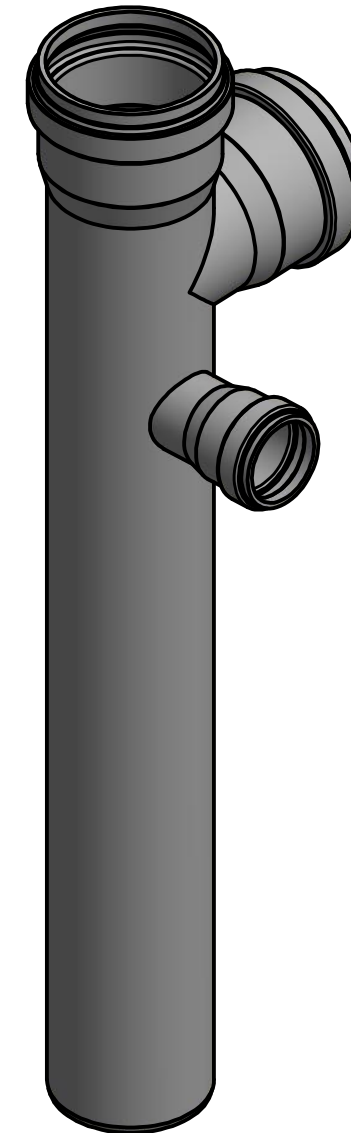

A-A ( 1 : 5 )

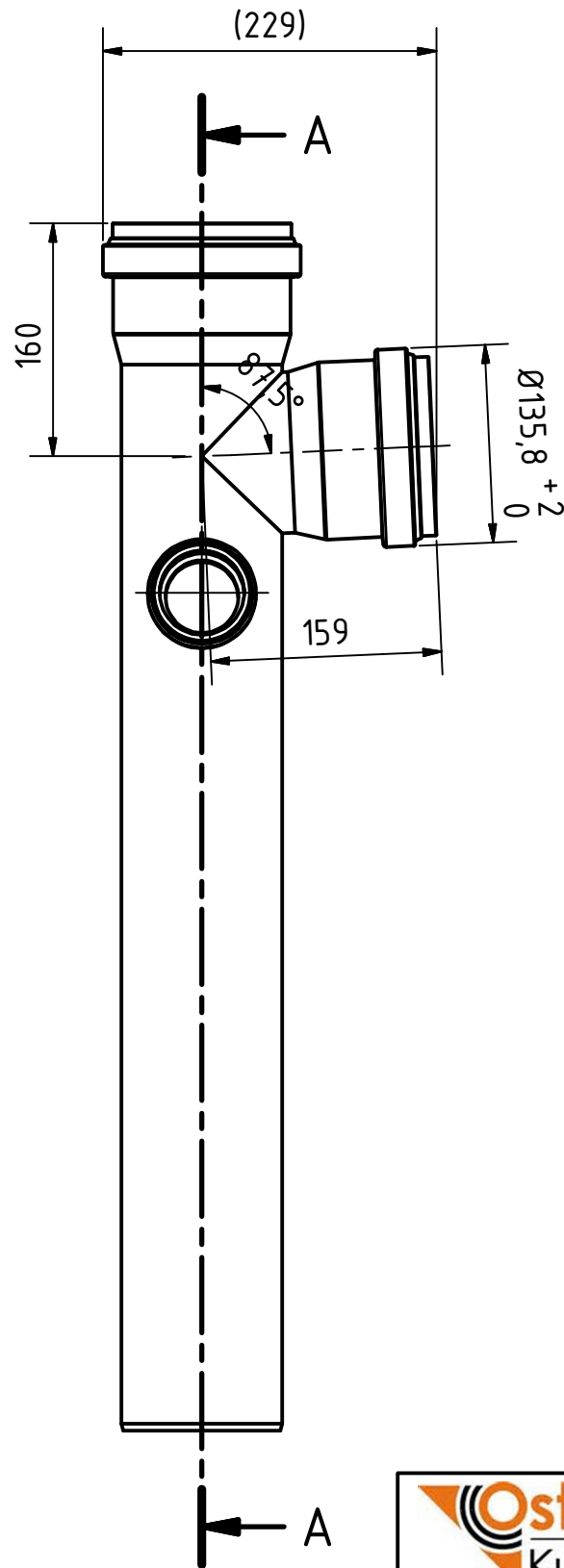
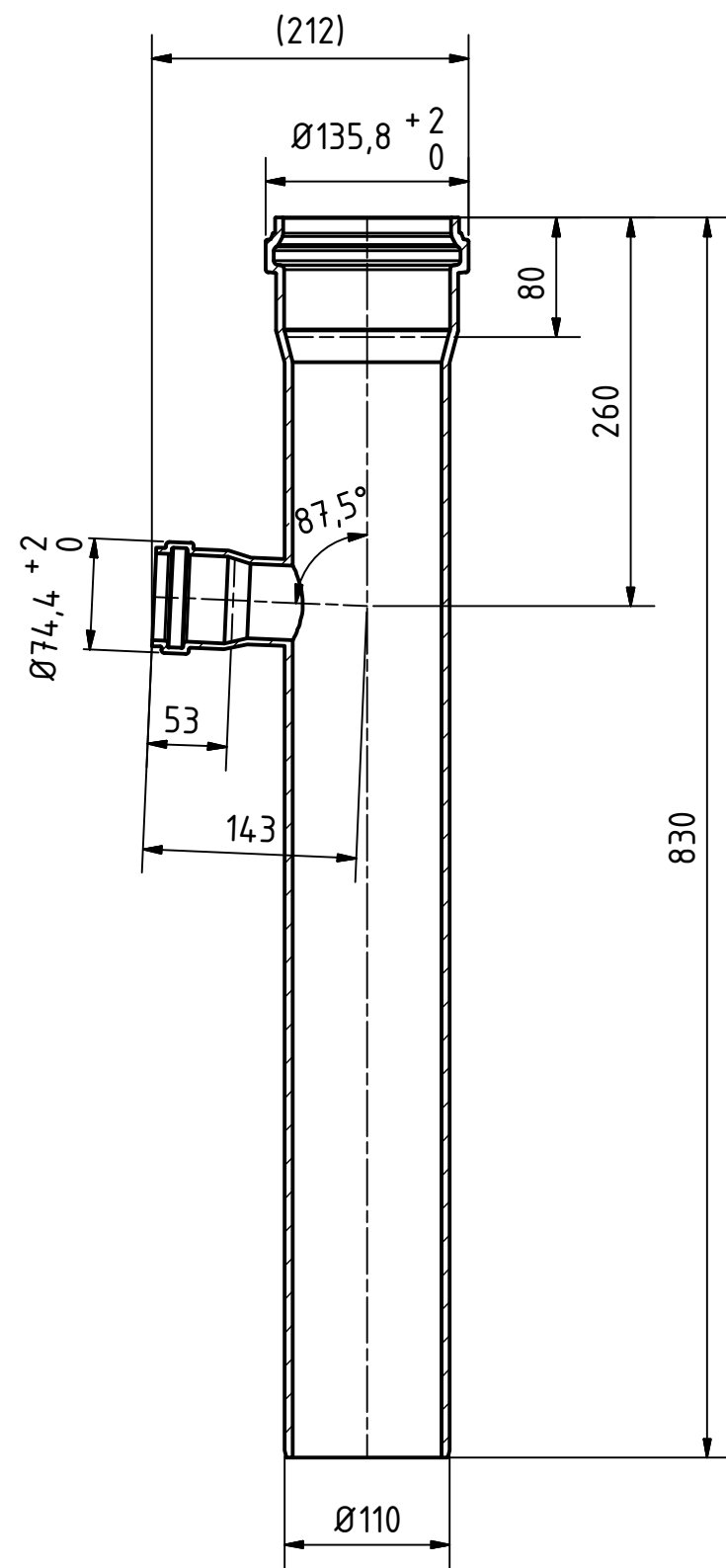

		Maße nach Z-42.1-217		Art.Nr.: 335680		Maßstab 1:5		
				Material: PP-MD				
		Datum		Name		<h1>Skolan Safe</h1>		
		Gezeichnet 16.07.2018		A.Schmedes				
		Kontroll.						
Status	Änderungen	Datum	Name	Norm				
Gebr. Ostendorf Kunststoffe GmbH Rudolf-Diesel-Str. 6-8 D-49377 Vechta verkauf@ostendorf-kunststoffe.com www.ostendorf-kunststoffe.com						SKOLANsafe Duschkoppelabzweig DN/OD 110/110/58 links		1
						Schutzvermerk nach DIN ISO 16016 beachten!		A3